

# Technical Specifications

4KSW-7.5-4H

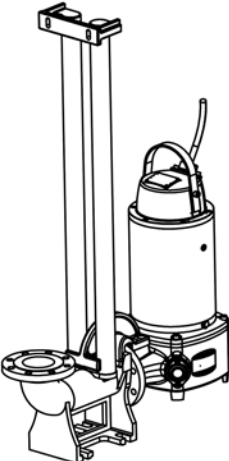

# 1. Technical Data

<b>Product</b>	Submersible pump for pumping clean water, surface water and waste water containing solid or long-fibered material.	
<b>Models</b>	Product model number	4KSW-7.5-4H
	Installation	GR, FS, DV, DH
	Impeller characteristics	Semi Open Type, 2 Vane
<b>Process Data</b>	Liquid temperature-standard	32~104°F(0~40°C)
	Maximum depth of immersion	164ft(50m)
	The pH of the pumped Liquid	5.5 ~ 14
	Liquid density	Max. 1,100 kg/m <sup>3</sup>
	Solid handling	75mm(3 inch)
<b>Motor Data</b>	Frequency	60Hz
	Phase	Φ3
	Rated motor power	7.5HP(5.5kW)
	Motor efficiency	86.5%
	Rated current	23.0/11.5A
	Starting current	A
	Power factor	0.83
	Rated motor speed	1750rpm
	Number of poles	4
	Full load torque	23lb·ft (30N·M)
	Locked rotor torque	190%
	Breakdown torque	220%
	Insulation class	H (IEC85)
	Voltage variation - continuously running	Max. ±5%
	- intermittent running	Max. ±10%
	Voltage imbalance between phases	Max. 2%
	No. of starts/hour	Max. 20(evenly spaced)
<b>Cable</b>	Direct-on-line (460V/380V)	PNCT 4G2.5+4G1.5
	Direct-on-line (230V/220V)	PNCT 3G4+1G2.5+4G1.5
	VFD application	-
<b>Motor Protector</b>	Thermal contacts opening temp.	248°F(120°C)
	Leakage sensors	Electrode Type
	Bearing temp. sensors	optional
	Vibration sensors	optional

<b>Materials</b>	Impeller	Grey Cast Iron SS 304, 316L, Duplex (optional)
	Pump & motor casing	Grey Cast Iron SS 304, 316L, Duplex (optional)
	Shaft	SS 410
	O-ring	NBR Viton(optional)
	Mechanical seal face (rotational/stationery)	SiC/SiC WC/WC (optional)
	<b>Surface Finishing</b>	All cast parts are primed with a water-borne primer. The finishing coat is a high-solid two pack paint. Standard paint color is deep blue(5PB3.5/1.5)
	<b>Weight</b>	See dimensional drawing.
<b>Option</b>	Explosion proof design PII(Plasma Ion Injection) surface hardening	
<b>Accessories</b>	<ul style="list-style-type: none"> <li>• Mechanical: discharge connection, flush valve, adapter, hose connection</li> <li>• Electrical: pump controller, control panels, starters, monitoring relays, cables</li> <li>• Anti-Corrosion: zinc anode</li> <li>• Spare parts</li> </ul> <p>Visit <a href="http://www.khydropumps.com">www.khydropumps.com</a> for more information.</p>	

## 2. Performance Curve

### Q-H Curve

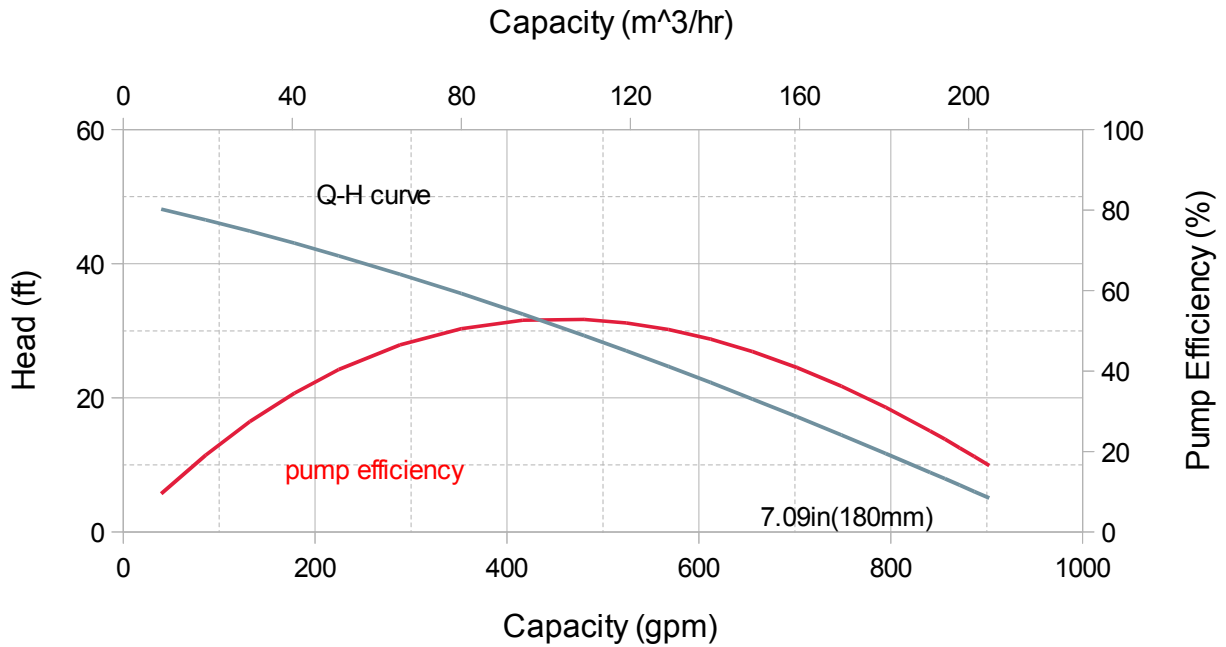

### Shaft Horse Power

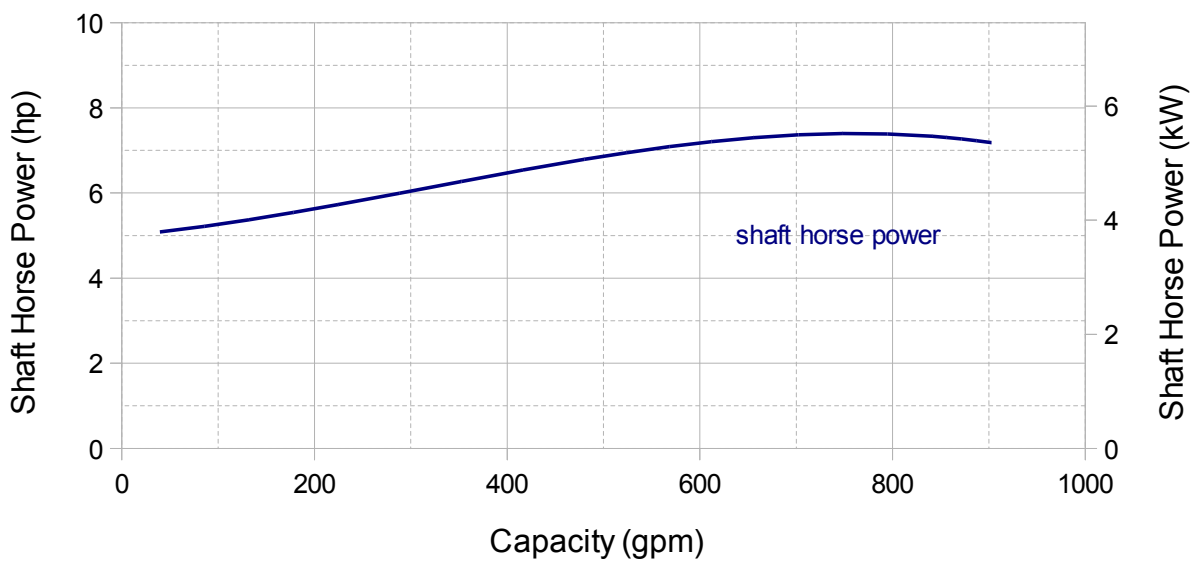

※ Performance with clear water and ambient temp 20°C (68°F)

# 3. Dimensional Drawing

## Wet Pit, Auto Coupling System Installation (GR-Installation)

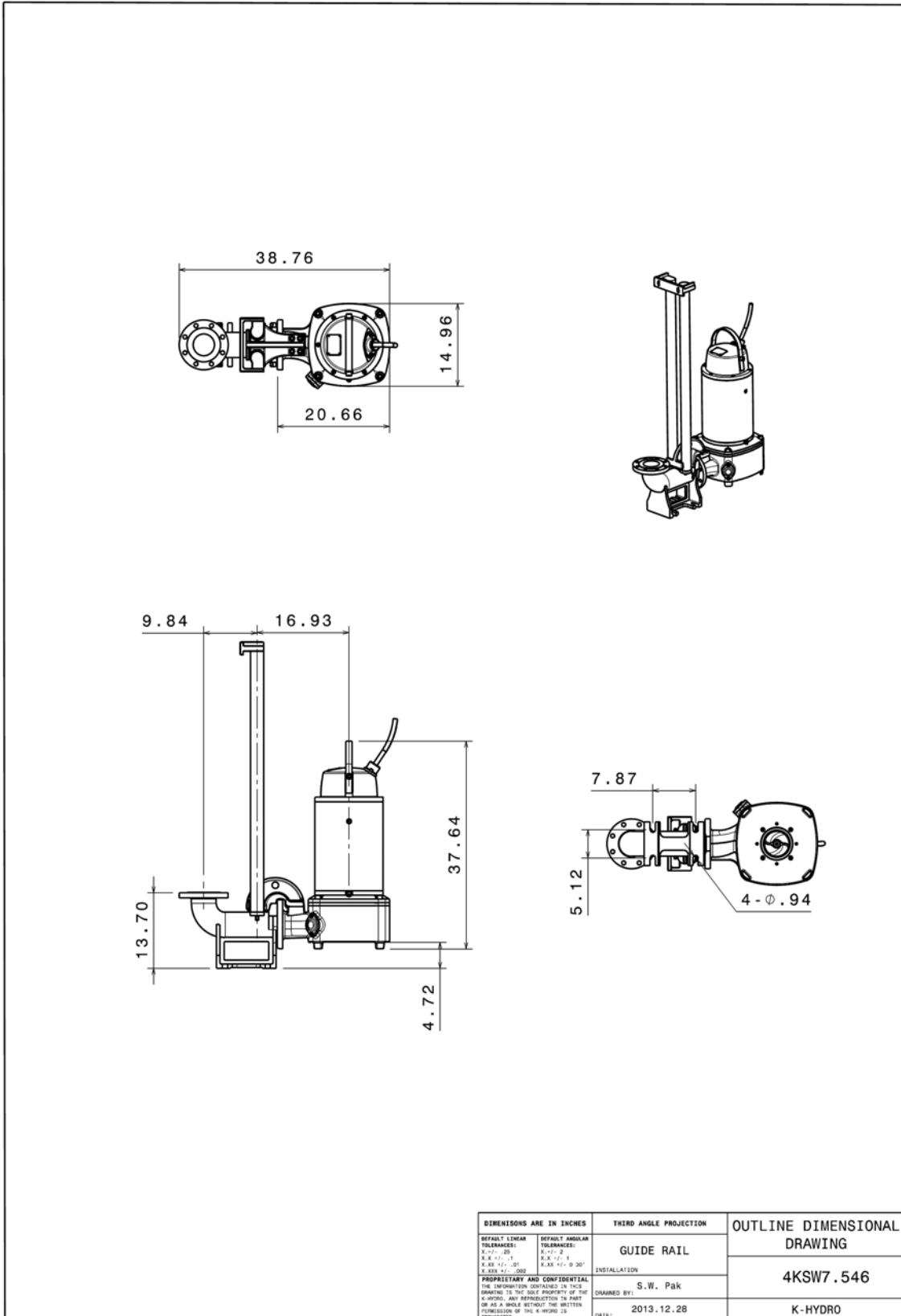

## Wet Pit, Free Standing Installation (FS-Installation)

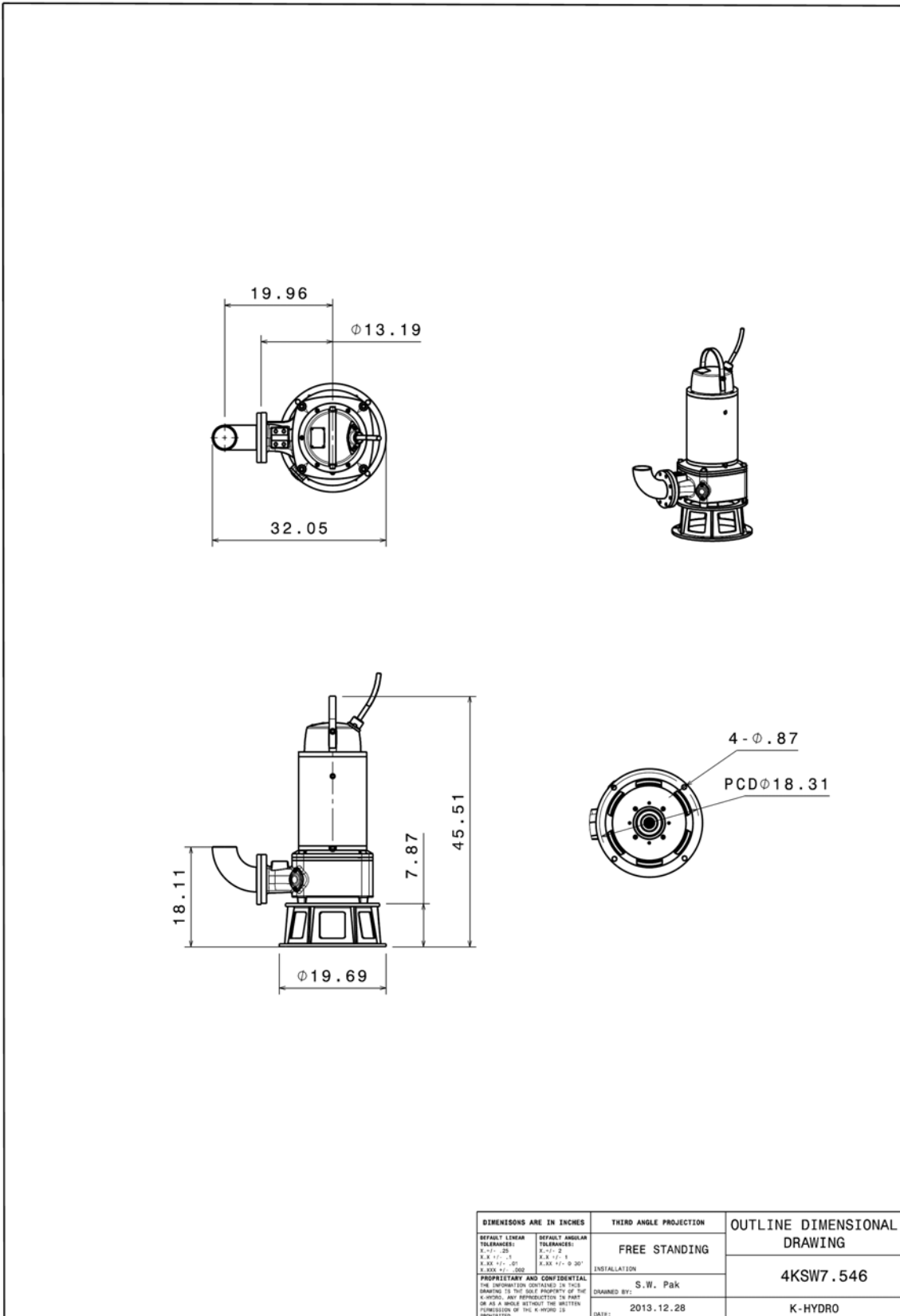

## Dry Pit, Vertical Installation (DV-Installation)

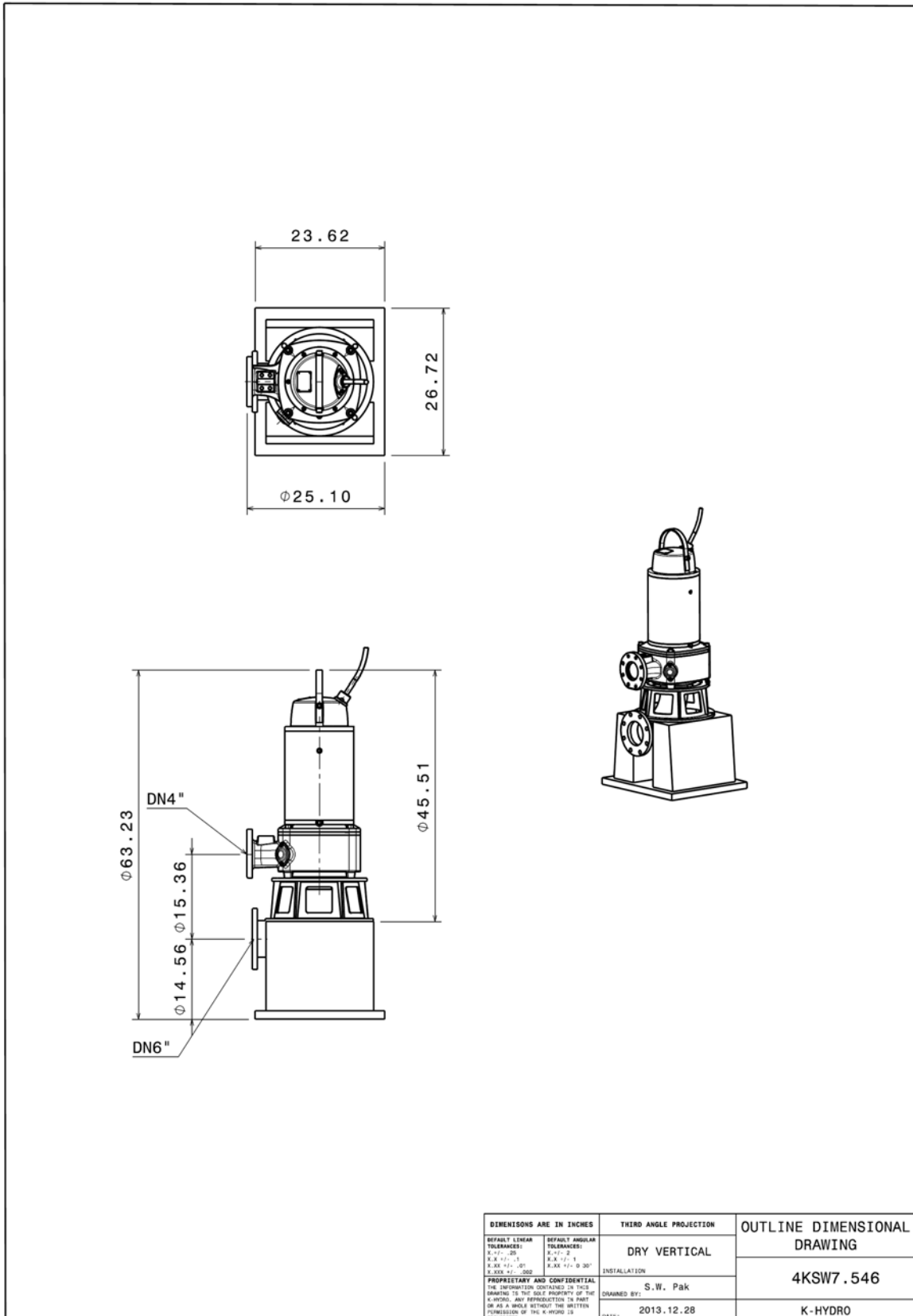

## Dry Pit, Horizontal Installation (DH-Installation)

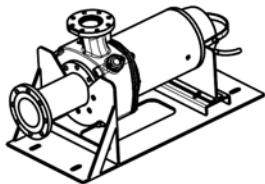
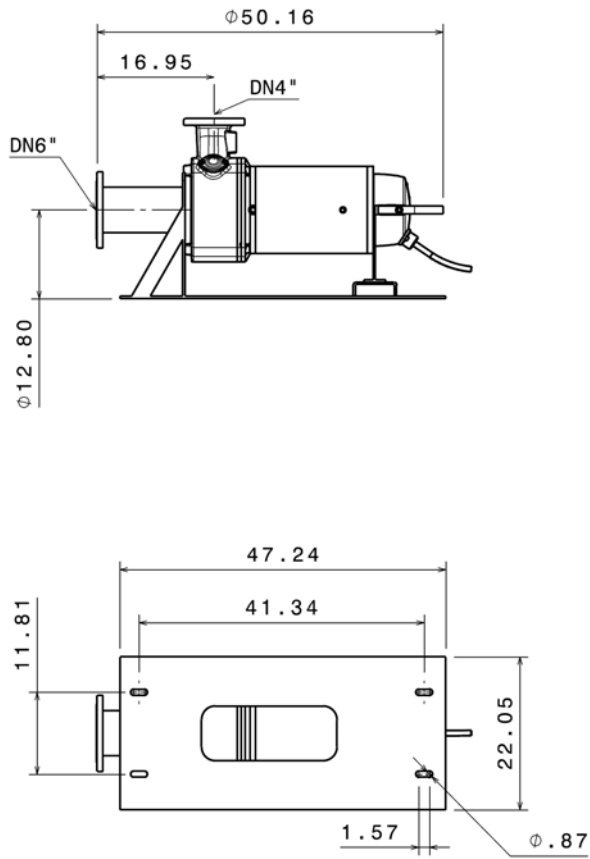

DIMENSIONS ARE IN INCHES		THIRD ANGLE PROJECTION	OUTLINE DIMENSIONAL DRAWING
<b>DEFAULT LINEAR TOLERANCES:</b> X.X +/- .25 X.XX +/- .1 X.XXX +/- .05 X.XXX +/- .002	<b>DEFAULT ANGULAR TOLERANCES:</b> X.X +/- 2 X.XX +/- 1 X.XXX +/- 0.30°	DRY HORIZONTAL  INSTALLATION	4KSW7.546
<b>PROPRIETARY AND CONFIDENTIAL</b> THE INFORMATION CONTAINED ON THIS DRAWING IS THE SOLE PROPERTY OF THE K-HYDRO. ANY REPRODUCTION IN PART OR AS A WHOLE WITHOUT THE WRITTEN PERMISSION OF THE K-HYDRO IS PROHIBITED.		S.W. Pak DRAWN BY:	K-HYDRO
		DATE: 2013.12.28	





**K-Hydro is a leader in submersible pumping technology.**

We have engineered many successful installations throughout Asia, Europe, and North America. Our proven track record in this specialized product range is one of the best in the industry. Our broad product range extends from 1HP dewatering pumps to 1,600HP propeller pumps. The quality, reliability and overall performance of our products combined with our strong service support will result in lower total life cycle costs for your submersible equipments.

Visit our website for the latest version of this document and more information

**[www.khydropumps.com](http://www.khydropumps.com)**

---

K-Hydro Pumps

803 North Myrtle Avenue, Jacksonville, FL32204

Tel: 800-730-4448 Fax: 904-356-8717 Email: [sales@khydropumps.com](mailto:sales@khydropumps.com)